



1-877-919-JEEP www.ironrockoffroad.com

Instructions

Parts Checklist:

- Logo decal 10001 (Qty: 1)
- Rock-Link Decal 13287 (2)
- Ironrockoffroad.com decal (1)
- 4" Front springs 96006 (2)
- 4" Rear springs 96007 (2)
- Rear coil spring retainer 92040 (2)
- WJ Adjustable front track bar 92001 (1)
- Track bar male threaded end 92004 (1)
- Rear sway bar link, 13.5" center to center 92148 (2)
- Front JKS Sway bar quicker disconnect set 3104 (1)

#1 - Front Track Bar Hardware (1)

- Track bar bushing half M20919 (4)
- 12mm track bar bushing sleeve 92035 (2)
- 7/8-14 Jam Nut (1)

#2 - Rear Sway Bar Link Hardware (1)

- 3/4" hourglass bushing M00393 (4)
- 12mm sway bar bolt sleeve 92038 (2)
- 10mm sway bar bolt sleeve (2)
- M10 x 60 sway bar link bolt 92037 (2)
- M10 X 1.5 hex nut (2)
- 7/16 USS washer (2)

#3 - Shocks Hardware (1)

- 12mm shock bolt sleeve 404739 (2)
- 7/16" washer (6)
- 5/16 x 1 hex bolt (4)
- 5/16-18 hex nut (4)
- 5/16 washer (8)

#23 - Coil Spring Retainer Hardware (1)

- 7/16-14 x 5" Socket head cap screw (2)

BOX 1: 13319 (1)

- Front Subframe center 92270 (1)
- Front Subframe left outer 92256 (1)
- Front Subframe right outer 92275 (1)
- T-Case drop spacer 88264 (2)

#183 - 3-Link Long Arm Subframe Hardware (1)

- Nut Plate 92097 (2)
- M14 x 2.0 x 90 hex bolt class 10.9 (1)
- M14 x 2.0 x 110 hex bolt class 10.9 (2)
- M14 x 2.0 x 120 hex bolt class 10.9 (2)
- 7/16-14 x 1 1/4 hex bolt grade 8 (4)
- M10 x 1.5 x 30 hex bolt class 10.9 (4)
- M10 x 1.5 x 60 hex bolt class 10.9 (4)
- M10 x 1.5 x 80 hex bolt class 10.9 (5)
- M14 x 2.0 nylock flange nut class 10.9 (5)
- M10 x 1.5 nylock flange nut class 10.9 (1)
- 9/16 F436 hardened washer (5)
- 7/16 F436 hardened washer (13)
- 1/4" Rubber trim edging (3")

BOX 2: 13490 (1)

- WJ Long LCA Left Front 85107 (1)
- WJ Long LCA Right Front 85108 (1)
- WJ 3-Link Front UCA 92277 (1)
- Angled Long Arm Male End 91109 (2)
- 2 3/8 UCA Male End 91191 (1)
- Front coil spring retainer 92040 (2)

#6 - Front Brake Line Spacers, Coil Spring Retainer Hardware (1)

- Front brake line spacer 92037 (2)
- M6 x 45 Front brake line bolt (2)
- 1/4" USS washer (2)
- 1/2 x 5" socket head cap screw (2)

#78 - Control Arm Spacer Hardware (1)

- Control arm spacer 90194 (4)

#127 - 2 5/8" 6 Bolt IRO Flex End Hardware (2)

- Inner race 91118 (2)
- Thrust washer 91119 (2)
- 2-5/8" Flex End Ball 91117 (1)
- 10-32 x 1-3/4" Socket Head Cap Screw (6)
- 10-32 Nylock Nut (6)
- 1/4"-28 90° Grease zerk Fitting (1)

#168 - 2-3/8" Flex End Hardware (1)

- End cap 91138 (2)
- Inner race 91139 (2)
- Flex end ball 91140 (1)
- 8-32 x 1-1/2" socket head cap screw (8)
- 1/4"-28 90° grease zerk fitting (1)
- 1/4"-28 straight grease zerk (1)

#181 - 3-Link Control Arm Clamping Hardware (1)

- 1/4"-28 x 1-1/8" socket head cap screw (4)
- 3/8-16 x 1 1/4" hex bolt grade 8 (1)
- 1/4"-28 hex nut, grade 8 (4)
- 3/8-16 nylock flange nut (1)
- 3/8 Mil spec washer 95229A480 (1)

BOX 3: 14005 (1)

- WJ rear 4-Link crossmember 92244 (1)
- WJ rear 4-Link axle bracket 90234 (1)

#160 - WJ 4-Link Crossmember Hardware (1)

- 7/16-14 x 1-1/4" gr8 hex bolt (10)
- 7/16 USS washer (10)
- 7/16-14 Serrated flange nut (2)
- M14 x 100 cl10.9 hex bolt (4)
- 9/16" USS washer (8)
- M14 cl10.9 hex nut (4)
- 2 hole nut plate 92097 (4)

#161 - WJ 4-Link Axle Bracket Hardware (1)

- M14 x 35 cl10.9 hex bolt (3)
- M14 x 110 cl10.9 hex bolt (2)
- M14 x 120 cl10.9 hex bolt (2)
- 9/16 USS washer (4)
- M14 cl10 nylock flange nut (4)
- 1/4" control arm spacer 90194 (4)

BOX 4: 13507 (1)

- WJ rear long uca 92214B (2)
- WJ left rear long lca 85109B (1)
- WJ right rear long lca 85110B (1)
- WJ Long Arm Male End 92186 (4)

#65 - Adjustable LCA Clamping Hardware (2)

- 1/4-28 x 1-1/8" Socket head cap screw (4)
- 1/4-28 gr8 Hex nut (4)

#127 - 2-5/8" 6 Bolt IRO Flex End Hardware (4)

- Inner race 91118 (2)
- Thrust washer 91119 (2)
- Ball 91117 (1)
- 10-32 x 1-3/4" Socket Head Cap Screw (6)
- 10-32 Nylock Nut (6)
- 90 Degree 1/4"-28 Grease Zerk Fitting (1)

Shocks

- IRO HD Hydro**
 - Front Shock 79001 (2)
 - Rear Shock 79004 (2)

(Optional) Doetsch Upgrade

- Front shock DT 8350 (2)
- Rear shock DT 8299 (2)

#9 - Shock Hardware (1)

- Front Shock barpin 403827 (2)

(Optional) Bilstein Upgrade

- Front shock 33-230351 (2)
- Rear shock 33-185552 (2)

#9 - Shock Hardware (1)

- Front Shock barpin 403827 (2)

ROCK-LINK



Installation Instructions:

Safety Warning: ***Important! Read before installation. ***

We recommend this system be installed by a qualified professional. Knowledge of suspension component function is necessary for safe installation and post installation inspections. Be sure to re-torque all suspension components after the first 100 miles of use, and frequently inspect all safety critical suspension components.

Before you begin:

- Read all safety warnings.
- Read and understand installation instructions.
- A custom exhaust or IRO 4-link exhaust kit (13509) will be required. Factory exhaust will not work.
- Check all steering and suspension components for wear and replace as needed.
- Contact Iron Rock Off Road with any questions before, during, or after installation.
- Ensure that all parts are present and in good condition using the included shipping checklist *PRIOR* to scheduling installation.**
- Be sure you have the following tools and supplies:
 - Floor jack and jack stands.
 - Basic hand tools (wrenches, sockets, etc.)
 - Multi-purpose grease.
 - Metal cutting tools such as a 4 1/2" angle grinder with thin metal cutting wheel, and a sandpaper flap wheel for an attractive finish. Possibly a Sawzall with metal cutting blades.
 - Paint and primer (for uniframe - black or your choice of color).
 - 1/2-20 (fine thread) Hand tap and tap handle
 - High Strength Thread locker such as Lock-Tite Red
 - String level, laser level and slope gauge or angle finder.
 - Hand drill with good quality 7/16" drill bit
 - Anti-seize compound for bolts

Notes:

- If your transfer case is an NP242WJH (32 spline) and your rear drive shaft is equipped with a harmonic balancer (see picture). Additional parts may be required. See step 73
- This suspension lift kit requires a **front** double cardan driveshaft. Some WJs come equipped with a double cardan front driveshaft from the factory. The OEM double cardan front driveshaft will work with this kit. If your WJ does not have a front double cardan driveshaft IRO sells a conversion kit (Code: 10374)



WJ Front Driveshaft Conversion Kit (Code: 10374)



- Contact Iron Rock Off Road with any questions before, during, or after installation.
1-877-919-JEEP
1-952-210-7185

Prepare the parts for Installation:

1. **Shocks:** Locate hardware kit 3 and the rear shocks.
2. Grease and install the 5/8" I.D. shock bushings included with the shocks.
3. Grease and install the four 12mm shock bolt sleeves (two from hardware kit 3, two included with the shocks). The rear shocks use 12mm sleeves at the top and bottom.
4. Grease and install barpins into the lower end of the front shocks as shown in **figure 1**.
5. Leave the rest of the hardware in the bag for future use.
6. **Track Bar:** Locate the front track bar male end, and hardware kit 1.
7. Install the jam nut onto the threaded end of the track bar.
8. Apply anti-seize and thread male end into track bar.
9. Grease and install the track bar bushings and bolt sleeves
10. Pre-adjust the track bar to a length of 32-3/4" center to center as a starting point. Do not tighten jam nut at this time.
11. **Sway Bar Links:** Locate the rear sway bar links (13.5" center to center) and hardware kit 2.
12. Grease and install the hourglass bushings.
13. Grease and install the sway bar link bolt sleeves. Each rear link gets one 12mm I.D. sleeve and one 10mm I.D. sleeve.
14. Leave the rest of the hardware in the bag for future use.
15. Locate the front JKS sway bar links.
16. Assemble JKS sway bar links according to their instructions.
17. **Front Arms:** Locate the lower control arms (larger, threaded male ends (larger, angled), hardware kit 127 and 181.
18. Locate the upper control arm (smaller, treaded male end (smaller, straight), and hardware kit 168.

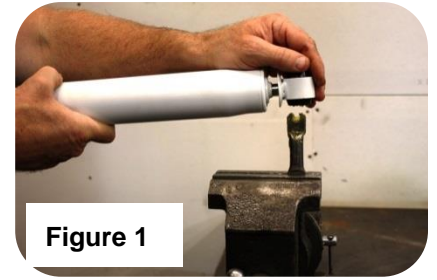

Figure 1



Threaded Male End

Lower Control Arms

Control Arm Length (Starting Lengths - Center to Center)	
Front Lower Control Arms	36-1/2" (Short Side)
Front Upper Control Arm	33"
Rear Lower Control Arms	39" (Short Side)
Rear Upper Control Arms	29-7/8"

19. Assemble flex ends into lower control arm male ends. Use hardware kit 127 and attached instructions (2-5/8").
20. Assemble flex end into upper control arm male end. Use hardware kit 168 and attached instructions (2 3/8").
21. Apply a light coat of anti-seize compound to the threads and thread the male ends into control arms.
22. Adjust upper and lower control arm lengths per the chart as a starting point.
23. Install clamping bolts. Do not tighten at this time.
24. **Rear Arms:** Locate four control arms, male ends, and hardware kits 127 & 65.
25. Build control arms: Assemble flex ends per attached instructions (last page).
26. Apply anti-seize to male threads and thread into the control arms. All male ends are the same.
27. Adjust upper and lower control arm lengths per the chart as a starting point.
28. Install clamping bolts. Do not tighten at this time.
29. With vehicle on level ground, measure the rear pinion angle. Hold a straight edge (steel ruler, flat steel plate) against the pinion seal metal body, then measure the angle with a slope gauge.
30. Record pinion angle here _____.

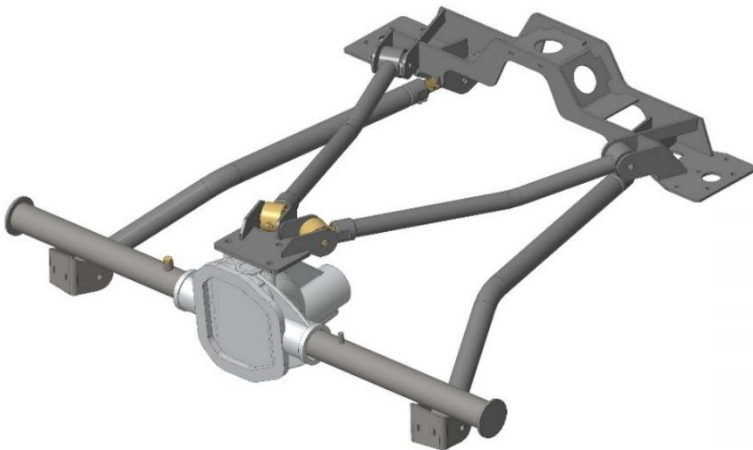

****NOTE****
To minimize downtime of your Jeep:
 The front subframe can be installed without affecting the ability to drive your Jeep.

Control arm mounting subframe:

31. Lift front and rear of vehicle and support with jack stands under the uniframe. Leave room to cut off the stock lower control arm mounts.
****Tip: break lug nuts loose before lifting vehicle. ****
32. Raise transfer case **very** slightly and support with a jack stand.
33. Remove the transmission mount bolt and nut from the transmission crossmember.
34. Remove the factory transmission mounting crossmember.
35. Locate the left and right subframe outers and hardware kit #183.
36. Add rubber edging to left subframe outer as shown in the picture.
37. Remove two plastic clips from the fuel lines on the left side of the frame. (arrows)

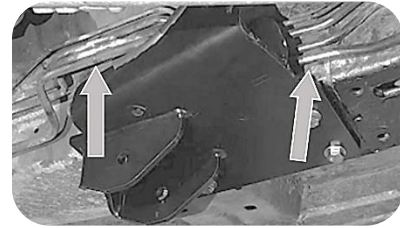

38. Install the new subframe left and right outers using provided M10 x 30 flange and M10 x 80 bolts in the same holes that held the factory crossmember. Be sure that the control arm mounting pockets are facing forward.
39. Tighten bolts firmly (bolts will be removed after drilling.)
40. Drill the additional 7/16" mounting holes, 2 per side at the front of each bracket.
41. Remove subframe outers. Remove any burrs and sharp edges around the holes. Clean, prime and paint any exposed metal.
42. Install nut plates into uniframe and position them over the drilled holes.
43. Install subframe outers using 7/16 x 1 1/4 bolts, M10 x 80 bolts and washers. Leave inside holes open to mount the subframe center section.
44. Install subframe center section using the T-Case drop spacers: align the spacers with the center section mounting holes and use M10 x 60 hex bolts. The notch in the spacer matches the notch in the center section.
45. Torque 7/16 bolts to 65-foot pounds. Torque M10 bolts to 34-foot pounds.
46. Lower the transfer case on to subframe.
47. Install the factory transmission mounting bolt and nut and torque to 78-foot pounds.

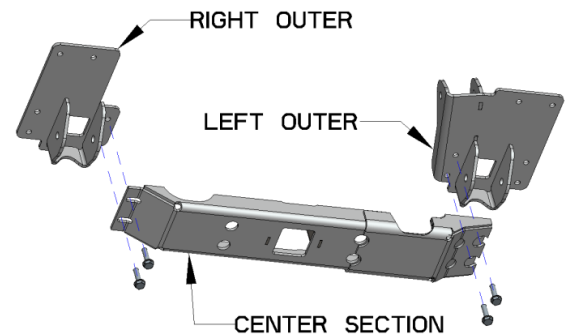

Front Suspension:

48. Remove upper and lower factory control arms, front shocks, track bar, springs and sway bar links.
49. Disconnect the driveshaft on the axle side and tape the u-joint so the caps do not fall off. Tie the driveshaft out of the way (use tape, zip tie, mechanic's wire, etc...) for easier access to the lower control arm mount.
50. Cut off factory lower control arm mounts from the uniframe on the driver's and passenger's side.
*****Tip: Our favorite tool for this is a 4 1/2" angle grinder with a thin cutting wheel. Remove in pieces for ease of access.*****
51. Clean up any burrs or sharp edges and grind smooth for an attractive appearance.
52. Clean, prime, and paint any exposed metal.
53. Locate Hardware Kit #6.
54. Install front brake line spacers between front brake line and axle where the brake line meets the shock mount. Use new M6 bolts and washers.
55. Locate the coil spring retainers (2" diameter x 5" long aluminum cylinders) and the remainder of hardware kit #6. The coil spring retainers bolt onto the front upper coil spring perch to keep the coil springs from falling out under extreme droop.
56. Using your 1/2-20 fine thread hand tap, tap the existing hole in the center of each front upper coil spring perch.
57. Apply high strength thread locker adhesive (such as Loctite red) to the threads of both 1/2" x 5" socket head cap screws.
58. Position the coil spring retainer onto the upper coil spring pad and install the bolt. Tighten firmly to 60 inch-pounds, do not over torque.
59. Install the upper control arm into the left subframe outer using M14 x 90 hex bolt, 9/16" washer, and M14 flange nut.
****Tip: Place M14 nut into an open-end wrench then slide it onto the back side of the subframe outer. Thread the M14 bolt into the nut.**
60. Install upper control arm with the threaded male end at subframe with the bend hanging down to clear the floor of the Jeep.
61. Torque upper control arm bolt on the chassis side to 135-foot pounds.
62. Connect the upper control arm to the axle using M10 x 80 bolt with washer and nylock flange nut. Do not tighten at this time.
63. Install Lower control arms with threaded adjusting end at the uniframe, and bends facing inward to clear the tires, thread clamping bolts facing down. Use provided M14 x 110 bolts at frame, M14 x 120 at axle, 9/16" washers, and nylock nuts. At the axle, use 2 control arm spacers per side, outboard of control arms.
64. Install new front track bar with adjustable end at the frame. Do not tighten jam nut at this time.
65. Install new front springs, sway bar links and new shocks using the factory hardware.
66. Do not tighten the control arm bolts at the axle at this time.

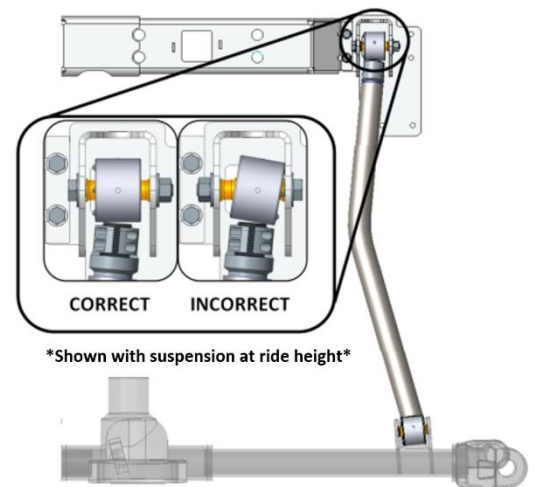

Rear Crossmember:

67. Lift rear of vehicle and support with tall jack stands under the unibody frame.
**Tip: break lug nuts loose before lifting vehicle.
68. Ensure that the vehicle is safely supported.
69. Remove rear tires.
70. Cut exhaust between catalytic converter and muffler. Remove tailpipe and muffler.
71. Removal of catalytic converter may be necessary depending on intended routing of new custom exhaust.
Recommended custom exhaust routing at the end of instructions
72. Locate crossmember and hardware kit 160.
73. Position crossmember with control arm tabs facing rear of vehicle.



NOTE: If you have the V8 with a NP242WJH (32 spline) transfer case and your rear drive shaft is equipped with a harmonic balancer (see picture) the balancer will interfere with the rear 4-link subframe. We offer 3 solutions:

- A. Install an IRO Hack-N-Tap Slip Yoke Eliminator (SYE) and a double cardan driveshaft.
 - B. Install a new driveshaft that doesn't have the balancer, or remove the balancer from your driveshaft.
 - C. Move the subframe forward 3/4" and lengthen the upper and lower control arms by 3/4".
74. Line up crossmember with the large holes in frame. Hold the subframe securely in place using a floor jack.
 75. Using the crossmember as a template, drill all ten 7/16 holes.
 76. Remove crossmember, deburr holes, and paint exposed metal.
 77. Insert nut plates into frame and position over 4 outer holes per side.
 78. Install crossmember with 7/16 bolts and washers.
 79. Install 7/16 bolt, washer, and serrated nut into center hole on each side.
 80. Torque all bolts to 65 ft-lbs.

Rear Suspension:

81. Place a floor jack under the center of rear axle for support (do not lift vehicle).
82. Loosen lower control arm bolts. Remove nuts but do not remove bolts.
83. Remove factory shocks, springs and sway bar links. Allow the rear suspension to droop as much as possible.
84. Locate 4-link axle bracket and hardware kit 161.
85. Raise rear axle up to a comfortable position to access the 3 a-arm retaining bolts on top of the differential.
86. Place a jack stand under the pinion to keep the axle from rotating.
87. Remove the 3 a-arm bolts on top of the differential.
88. Remove rear a-arm.
89. Install the 4-link axle bracket on the top of the differential using supplied M14x35 bolts.
90. Torque to 100 ft. lbs.
91. Install new upper control arms with the threaded male end located at the axle side. Do not tighten bolts at this time. Bend hangs down to clear the floor.
92. Locate lower control arms and 4 control arm spacers (1/4" thick washers).
93. Install new lower control arms with spacers on the outboard side of the bushings (pushing control arm towards center of vehicle), 2 at each axle bushing. Use the M14 x 120 bolts at axle and M14 x 110 at the frame. Do not tighten bolts at this time. Threaded male ends at the unibody. Bends face up for increased ground clearance, and inward to clear the uniframe.
94. Install new rear springs, sway bar links and new shocks using the factory hardware.
95. Do not tighten the control arm bolts at the axle at this time.



Adjustments and Final Inspection:

96. Raise vehicle and reposition jack stands under the front and rear axles.
97. Temporarily install tire on one side.
98. With full vehicle weight on the suspension, check if the axles are centered as desired in the wheel opening. Adjust lower control arms to desired front to rear axle position. Adjust rear upper control arms to desired pinion angle.
**Ensure your rear driveshaft has adequate engagement in the transfer case. See Picture
99. **Check front caster angle.** Using a laser level or string level, set the front axle level to the rear axle (left side and right). Bounce the Jeep up and down to ensure the suspension is in resting position (at exact ride height). Place the angle finder under the



axle "C" (or on top of the upper ball joint). Ensure the angle finder is parallel to the Jeep front to rear. This is your caster angle. See chart for desired setting.

100. Adjust control arms to the desired position.

- To adjust axle front to rear, adjust upper and lower control arms by the same amount. 12 turns equal one inch.
- To adjust only caster, adjust only the upper control arm (3 turns equals roughly 2 degrees).
- To adjust both, adjust both at the same time.

Caster angle may need to be adjusted after a test drive to eliminate driveline vibrations.

101. Check front axle position left to right. Adjust track bar length as needed. Tight jam nut very tight.

102. With full vehicle weight on the suspension, torque front upper control arm nut at the axle to 60-foot pounds.

103. With full vehicle weight on the suspension, torque front and rear lower control arm bolts and rear upper control arm bolts to 120-foot pounds.

104. Torque lower control arm clamping bolts to 140 in-lb. Be sure to go back and forth between both bolts several times to ensure even clamping.

105. Install tires and wheels. Torque lug nuts (Typical specification is 85-115 ft-lbs., depending on your wheels)

106. Recheck all fasteners and torque any remaining loose nuts or bolts to spec.

Front Caster Angle (Starting point)	
Lift Height	Caster
3.0"	5.5 degrees
4.0"	4.5 degrees
5.5"	3.5 degrees
6.5" – 8.0"	3.0 degrees



107. Check all components for clearance for suspension to fully cycle up and down and wheels to turn lock to lock. Pay special attention to brake lines, axle vent hoses, and ABS wires. Reposition as needed by bending the brackets, relocating, or extending hoses and wiring.

* A professional front end alignment is required after installation.* Recommended alignment settings:

Caster: +3.5 to +6.5 See chart above.

Toe-in: +1/16" to +1/8"

Final Safety Warning:

* Re-torque all fasteners after 100 miles, and frequently inspect all safety critical suspension components. It is the responsibility of the installer to ensure all fasteners are properly tightened after installation and to ensure the owner knows his/her ongoing responsibility. It is the responsibility of the owner of the vehicle to be sure all safety critical components are inspected frequently, especially after off road or other demanding use.



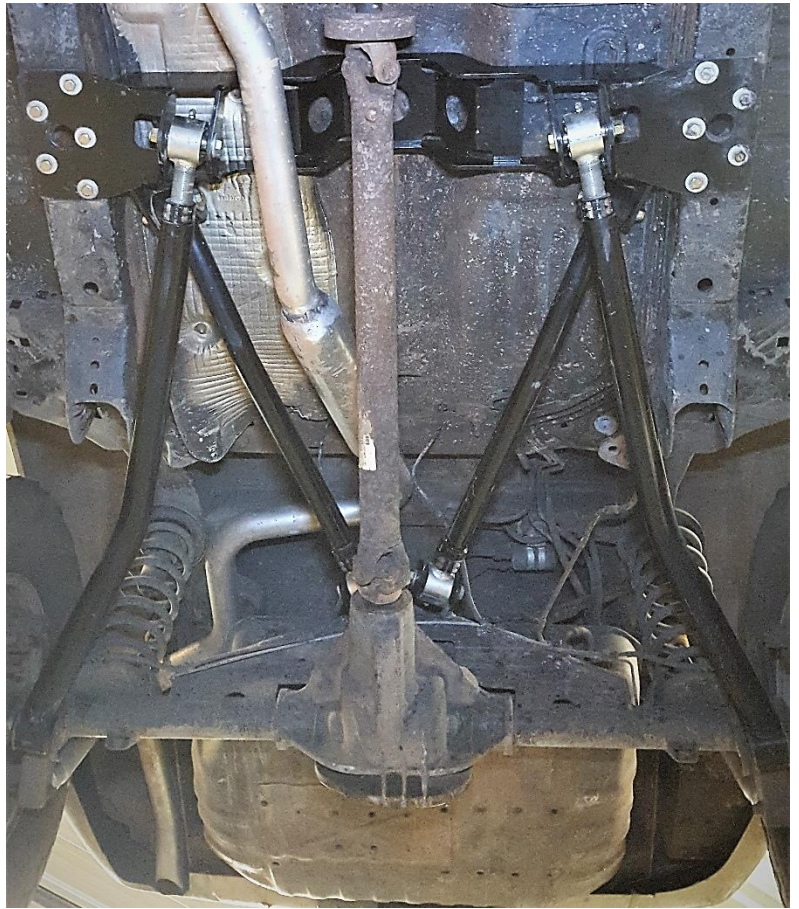

Iron Rock WJ 4-Link Exhaust Kit: 13509



Recommended custom exhaust routing

IRON ROCK OFF ROAD

2-5/8" IRO Flex End (6 bolt)

1-877-919-JEEP www.ironrockoffroad.com

Assembly Instructions

Fits All Iron Rock Off Road Long Arm Systems, WJ A-Arms, and Build Your Own Flex End Assemblies.

Before you begin:

- Read and understand installation instructions.
- Contact Iron Rock Off Road with any questions before, during, or after installation.
- **Ensure that all parts are present and in good condition per attached shipping checklist!**
- Have these tools handy:
 - 5/32" allen head socket
 - 3/8" open end wrench
 - Inch-lb. torque wrench
 - Multipurpose grease/grease gun

Parts Checklist:

- Outer housing, weld on (may already be attached to your existing control arm)

#127 - 2-5/8" IRO Flex End (6 bolt)

- 2-5/8" flex end race 91118 (2)
- Thrust washer 91119 (2)
- 2-5/8" flex end ball 91117 (1)
- #10-32 nylock nut (7)
- #10-32 x 1-3/4" socket head cap screw (6)
- 90° 1/4"-28 grease zerk fitting (1)



Figure 1

Assembly:

1. Insert two #10-32 socket head cap screws into one thrust washer and one plastic race. Spherical bore of race facing away from thrust washer. (Figure 1)
2. Install this small assembly into the flex end housing. The races are a light press fit, use a wide punch and hammer to assist you if needed.
3. Apply a thin coating of multi-purpose grease to the mating surfaces of the ball and both races.
4. Place the ball in the race (inside the flex end). The ball should perfectly fit the contour of the race. (Figure 2)
5. Insert the other race onto the ball so that the spherical bore is contacting the ball. Once again, the races are a light press fit, use a hammer and wide punch if needed. (The two screws should be through one washer and both races at this point)
6. Insert the second thrust washer on top of the flex end housing, sliding the bolts through the holes. (Figure 3)
7. Start nylock nuts on the two bolts that are in the flex end assembly. Hold the nut and turn the bolt.
8. Insert the remaining four cap screws through the remaining holes and install nuts. (Figure 4)
9. Snug up all of the bolts fairly tight.
10. Torque bolts evenly, starting at one bolt and continuing using a crisscross pattern. Torque all six bolts to 70 in-lbs., then to 85 in-lbs.
11. Install 90° grease zerk fitting so that it is easily accessed in the vehicle.
12. Grease flex end until grease comes out of the races around the ball.
13. Re-torque bolts to 85 in-lbs. after 5 minutes.

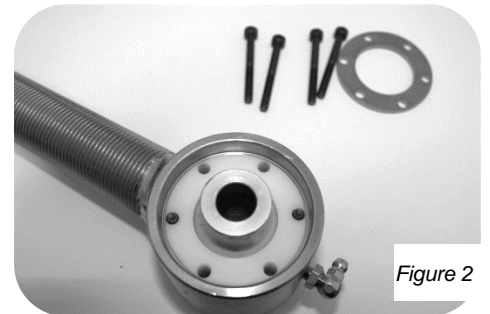

Figure 2



**Reference Only* Complete joint shown fully assembled without housing*

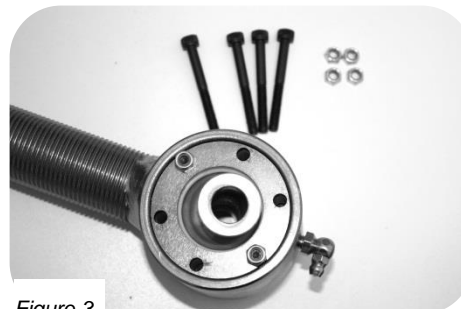

Figure 3

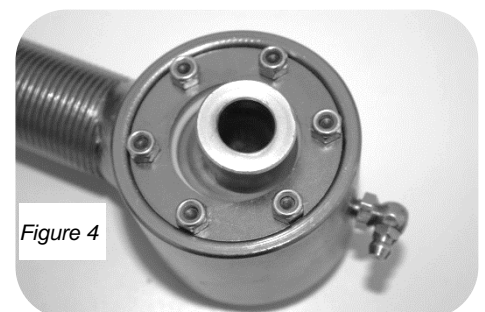

Figure 4

IRON ROCK OFF ROAD

2-3/8" IRO Flex End (8 bolt)
Assembly Instructions

I-877-919-JEEP www.ironrockoffroad.com

Before you begin:

- Read and understand installation instructions.
- Contact Iron Rock Off Road with any questions before, during, or after installation.
- **Ensure that all parts are present and in good condition per attached shipping checklist!**
- Have these tools handy:
 - 9/64" Allen head socket
 - 3/8" open end wrench
 - Inch-lb. torque wrench
 - Multipurpose grease/grease gun

Parts Checklist:

- Outer housing, weld on (may already be attached to your existing control arm)

#168 - 2-3/8" IRO Flex End (8 bolt)

- Inner race 91139 (2)
- Thrust washer 91138 (2)
- Ball 91140 (1)
- #8-32 x 1-1/2" socket head cap screw (8)
- 1/4"-28 90° grease zerk fitting (1)
- 1/4"-28 straight grease zerk fitting (1)

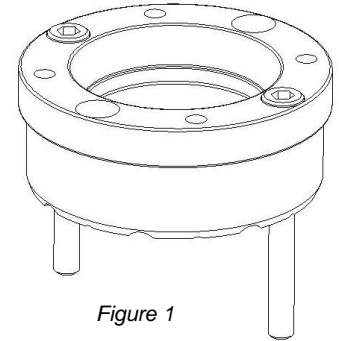
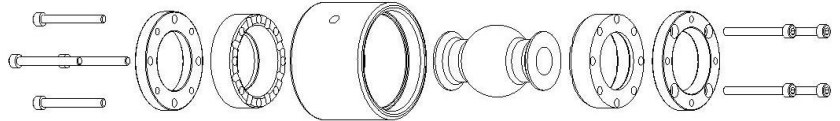
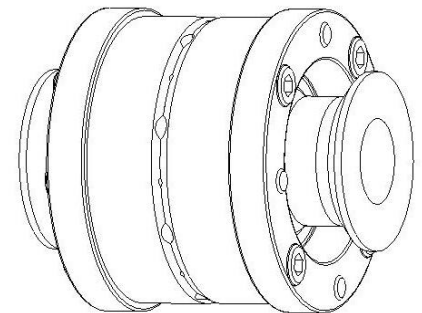

Figure 1

Assembly:

1. Insert two #8-32 socket head cap screws into one thrust washer and one plastic race. Spherical bore of race facing away from thrust washer. (Figure 1)
2. Install this small assembly into the flex end housing. The races are a light press fit, use a wide punch and hammer to assist you if needed.
3. Apply a thin coating of multi-purpose grease to the mating surfaces of the ball and both races.
4. Place the ball in the race (inside the flex end). The ball should perfectly fit the contour of the race.
5. Insert the other race onto the ball so that the spherical bore is contacting the ball. Once again, the races are a light press fit, use a hammer and wide punch if needed. (The two screws should be through one washer and both races at this point)
6. Insert the second thrust washer on top of the flex end housing, aligning the bolts with the threaded holes.
7. Start threading the two bolts into the threaded holes of the thrust washer. Do not fully tighten at this time.
8. Insert the remaining cap screws through the remaining holes and get them started in the threaded washer.
9. Snug up all of the bolts fairly tight. Go back and forth, rechecking each bolt several times to ensure even clamping
10. Torque bolts evenly starting at one bolt using a crisscross pattern, like torquing lug nuts. Torque all eight bolts to 50 in-lbs., then to 65 in-lbs.
11. Install 90° grease zerk fitting so that it is easily accessed in the vehicle.
12. Use a grease gun to grease the flex end through the zerk fitting. This will be difficult due to the tight tolerances in the flex joint assembly.
13. Re-torque bolts to 65 in-lbs.



**Reference Only* Complete joint shown fully assembled without housing*

